

© 1969 BY AMP INCORPORATED. ALL RIGHTS RESERVED. AMP PRODUCTS COVERED BY PATENTS AND/OR PATENTS PENDING.

REVISIONS				
ZONE	LTR	DESCRIPTION	DATE	APPROVED
✓	0	REL, WAS 5155-76 (CP17)	RHF 3-17-69	

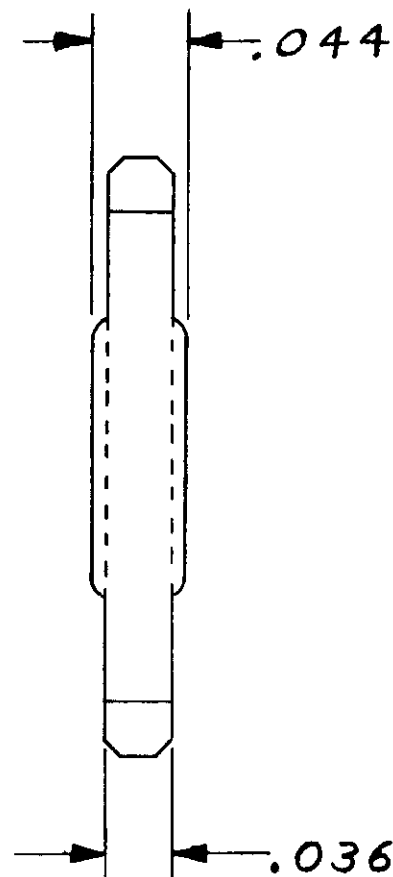
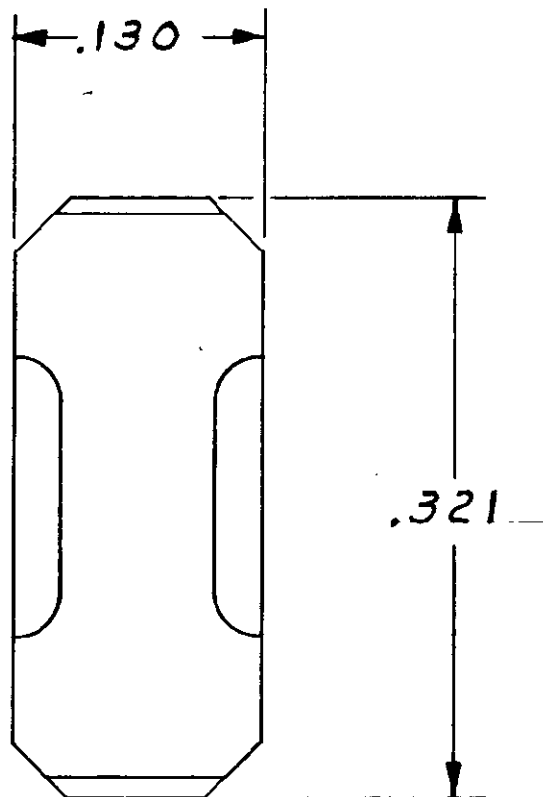

583462-1: 1.A5 SHOWN

△. MATL. NYLON
COLOR: NATURAL

LOC AD
PART DIST 0/14

UNLESS OTHERWISE SPECIFIED DIMENSIONS ARE IN INCHES TOLERANCES ON: DECIMALS ±.005 ANGLES ±	CONTRACT NO.		AMP INCORPORATED HARRISBURG, PENNSYLVANIA	
	DR. <i>M. Smith</i> 1-22-69	NAME		PLUG-KEYING, MODIFIED FORK CONNECTOR
	CHK. <i>...</i> 3/12/69	SIZE	CODE IDENT NO.	
	APPD. <i>J. Kaufman</i> 3/19/69	B	00779	
MATERIAL	REC. <i>R. Shawran</i> 3/21/69	NUMBER	583462	
△	DSGN APPD	SCALE	10-1	SHEET
	OTHER APPD			